METAWEARC
PRODUCT
SPECIFICATION v1.0



MetaWearC / CPro / CDetect / CEnv

Wearable and connected devices product solution

Product Specification v1.0

Key Features and Sensor Options

- Nordic Semiconductor nRF51822 BLE SoC
 - 2.4 GHz transceiver
 - ARM[®] Cortex™-M0 32 bit processor
 - 256 kB flash program memory
 - 16 kB RAM
- Optional Bosch[®] BMI160 6-Axis Accelerometer/Gyroscope
 - $\pm 2g/\pm 4g/\pm 8g/\pm 16g$ selectable scale
 - 125/250/500/1000/2000 degrees/sec
 - Industry Leading 900uA active current gyro
- Optional Bosch[®] BMA255 3-Axis Accelerometer
- Optional Bosch[®] BMM150 3-Axis Magnetometer
- Optional Bosch[®] BMP280 Digital Pressure Sensor
 - 30 to 110 kPa range
 - 0.16 Pa resolution
- Optional Bosch[®] BME280 Digital Humidity / Pressure Sensor
- Optional Lite-On[®] LTR-329ALS-01 Ambient Light Sensor
- Optional ams[®] TSL26711 Optical Proximity Sensor
- Optional ams[®] TCS34725 RGB Color Sensor
- Bright RGB LED
- Miniature push-button switch
- High current / haptic driver
- Accurate Thermistor Temperature Sensor
- I/O Expansion
 - Digital I²C Bus
 - 4 Analog/Digital Pins
 - 1 Digital Pin
- Tiny 24mm diameter x 6.5mm form factor
- Powered by low cost, easily sourced CR2032 Lithium Coin Cell
- FCC, IC, CE, Telec certification

Table of Contents

1	Introduction	5
2	Product Overview	5
2.1	Block Diagram	5
2.2	Model Feature Matrix	6
2.3	Pin Assignments	7
2.4	Pin Functions	8
2.5	Module to SoC Pin Mapping	9
3	Circuit and Sensor Details	10
3.1	High Current/Haptic Drive Circuit	10
3.2	Humidity / Barometric Pressure Sensor	10
3.3	Accelerometer / Gyroscope	10
3.4	Ambient Light Sensor	10
3.5	Mechanical Switch	10
3.6	Thermistor Temperature Circuit	11
3.7	RGB LED Circuit	11
3.8	Optical Proximity Sensor	11
3.9	RGB Color Sensor	12
3.10	32Mhz High Frequency Crystal	12
4	Absolute Maximum Ratings	13
5	Operating Conditions	13
6	Electrical Specifications	13
6.1	General Purpose I/O (GPIO) Specifications [C CPro CDetect CEnv]	13
6.2	Crystal Oscillator Specifications (OSC) [C CPro CDetect CEnv]	13
6.3	ADC (ADC) Specifications [C CPro CDetect CEnv]	14
6.4	Temperature Sensor (TEMP) Specifications [C CPro CDetect CEnv]	14
6.5	High Current Driver (HCD) Specifications [C CPro CDetect CEnv]	14
6.6	Accelerometer (ACCEL) Specifications [C CPro]	15
6.7	Accelerometer (ACCEL) Specifications [CDetect CEnv]	15
6.8	Gyro (GYRO) Specifications [C CPro]	15

6.9	Pressure (BAROMETER) Specifications [CPro CEnv].....	16
6.10	Humidity (HYGROMETER) Specifications [CEnv]	16
6.11	LED (LED) Specifications [C CPro CDetect CEnv]	16
6.12	Ambient Light (ALS) Specifications [CPro CDetect]	17
6.13	RGB Color + Ambient Light (COLOR, ALS) Specifications [CEnv]	17
6.14	Proximity Sensor (PROX) Specifications [CDetect]	17
7	Mechanical Specifications.....	18
8	Revision History	19
9	Regulatory Information for MetaWearC.....	20
9.1	Taiyo Yuden Radio Module Approval.....	20
9.2	CE Conformance.....	20
9.3	FCC Labeling Requirements	20
9.4	IC Labeling Requirements	20

1 Introduction

MetaWearC is a complete development and production platform for wearable and connected device applications. It features the ultra-low power nRF51822 SoC, providing energy efficient smartphone communication and central processing. MetaWearC integrates this radio with high value sensors and a coin cell battery architecture into a miniature form factor. All circuits have been designed from the ground up with energy efficiency in mind.

2 Product Overview

2.1 Block Diagram

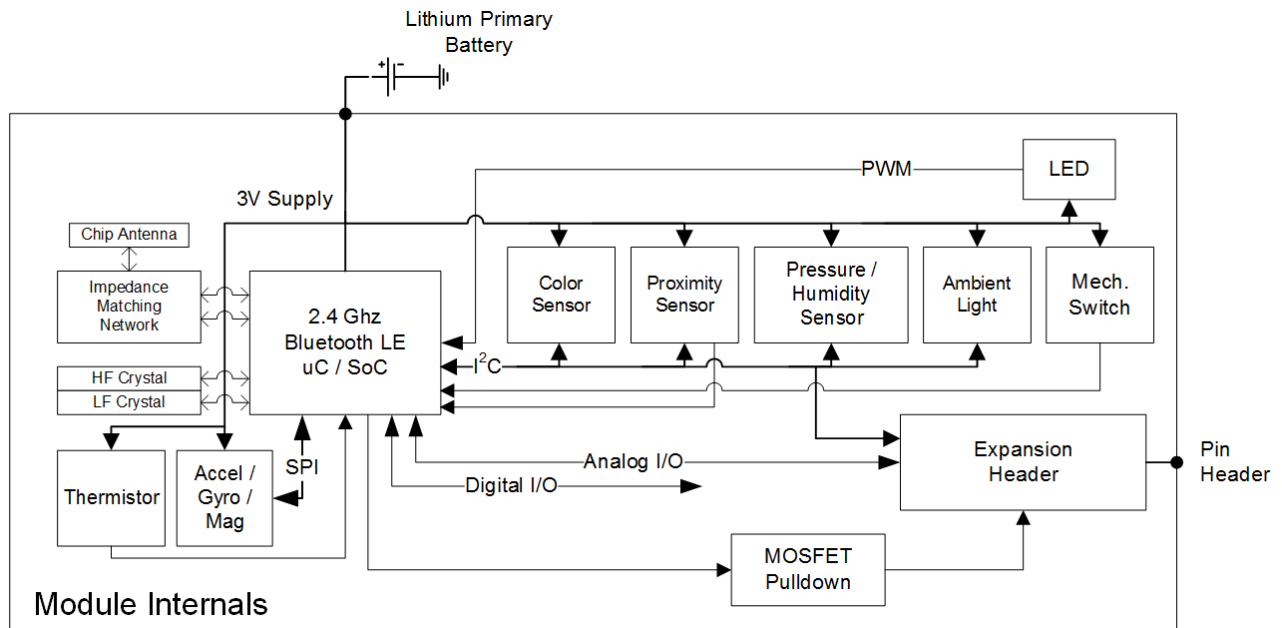

Figure 1 Block Diagram

2.2 Model Feature Matrix

Feature	C	CPro	CDetect	CEnv
Thermistor Temperature Sensor	X	X	X	X
High Current / Haptic Driver	X	X	X	X
Mechanical Switch	X	X	X	X
RGB LED Indicator	X	X	X	X
Accelerometer (BMI160)	X	X		
Accelerometer (BMA255)			X	X
Gyroscope (BMI160)	X	X		
Barometric Pressure (BMP280)		X		
Barometric Pressure (BME280)				X
Magnetometer (BMM150)		X		
Ambient Light (LTR-329ALS-01)		X	X	
Ambient Light (TCS34725)				X
Optical Proximity (TSL26711)			X	
RGB Color (TCS34725)				X
Humidity (BME280)				X

Table 1 Model Feature Matrix

MetaWearC devices with custom sensor combinations are available on special order.

2.3 Pin Assignments

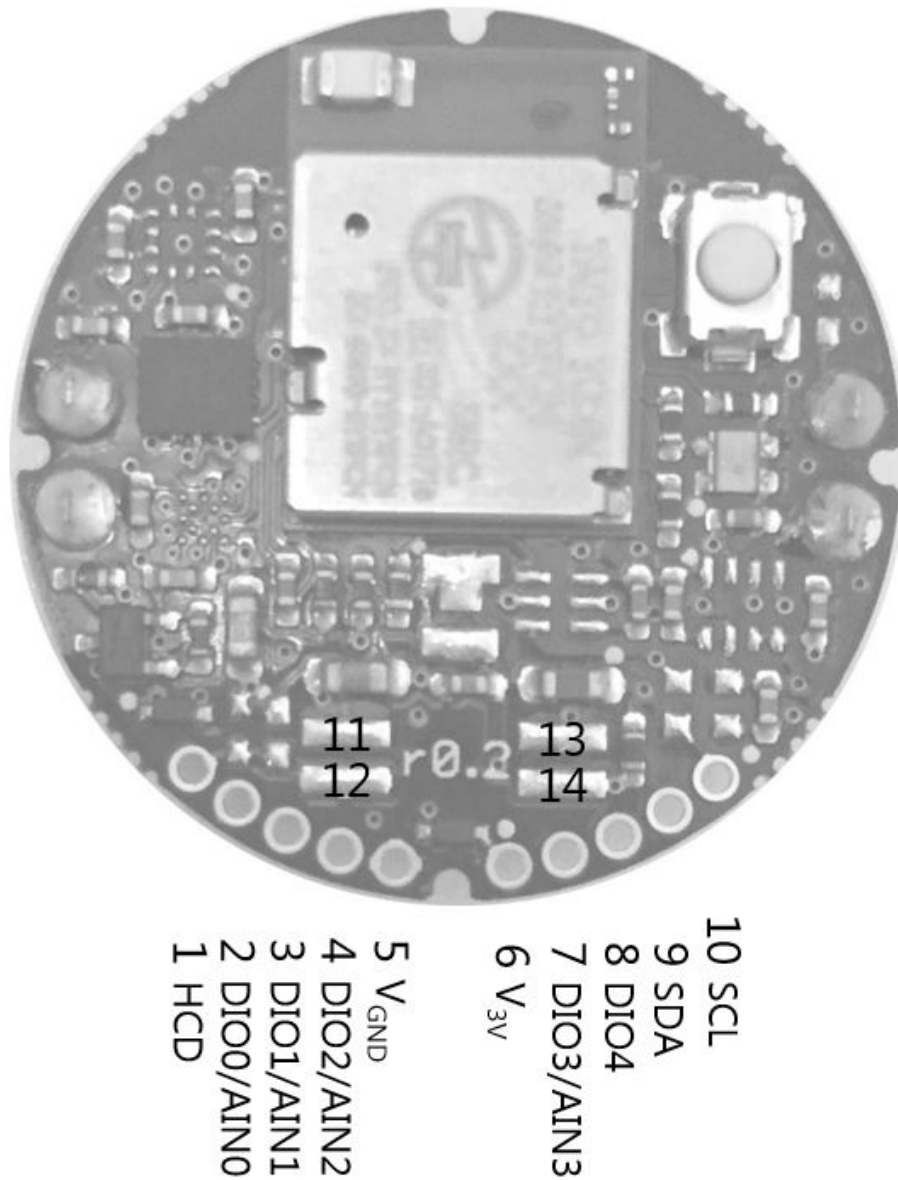

Figure 2 Pin Assignments

2.4 Pin Functions

Pin	Pin Name	Function	Description
Power Supply			
5	V _{GND}	Power	Ground connection.
6	V _{3V}	Power	+3V battery connection.
Peripherals			
1	HCD	High Current Driver	Switch for sinking high current peripherals.
2	DIO0 AIN0	Digital I/O Analog I/O	General purpose I/O and analog input.
3	DIO1 AIN1	Digital I/O Analog I/O	General purpose I/O and analog input.
4	DIO2 AIN2	Digital I/O Analog I/O	General purpose I/O and analog input.
7	DIO3 AIN3	Digital I/O Analog I/O	General purpose I/O and analog input.
8	DIO4	Digital I/O	General purpose I/O.
9	SDA	I2C Data	I2C data line.
10	SCL	I2C Clock	I2C clock line.
SWD Debug Header			
11	V _{3V}	Power	System supply for debugger.
12	V _{GND}	Power	System ground for debugger.
13	SWDIO/nRESET	Debug	SWD debugger I/O line and system reset.
14	SWDCLK	Debug	SWD debugger clock line.

Table 2 Pin Functions

2.5 Module to SoC Pin Mapping

Module Pin	nF51822 Pin	Function	Description
GPIO			
DIO0/AIN0	P0.06	GPIO	General purpose I/O and analog input.
DIO1/AIN1	P0.05	GPIO	General purpose I/O and analog input.
DIO2/AIN2	P0.04	GPIO	General purpose I/O and analog input.
DIO3/AIN3	P0.03	GPIO	General purpose I/O and analog input.
DIO4	P0.13	GPIO	General purpose I/O.
High Current/Haptic Driver			
HCD	P0.12	Haptic	Open Drain MOSFET Pull-down.
I2C			
SDA	P0.16	Serial Bus	I ² C serial data.
SCL	P0.18	Serial Bus	I ² C serial clock.
Internal Module Pins			
	P0.25	Switch	Micro Push Button. Active Low.
	P0.01	Thermistor En	Active High Enable for Thermistor.
	P0.02	Themistor Voltage	Voltage output from Thermistor Voltage Divider.
	P0.29	Acc/Gyro Interrupt	INT1 Pin of BMI160/BMA255.
	P0.28	Acc/Gyro Interrupt	INT2 Pin of BMI160/BMA255.
	P0.30	Acc/Gyro/Mag SCK	SCK Pin of BMI160/BMA255/BMM150.
	P0.00	Acc/Gyro/Mag MISO	MISO Pin of BMI160/BMA255/BMM150.
	P0.07	Acc/Gyro/Mag MOSI	MOSI Pin of BMI160/BMA255/BMM150.
	P0.11	Acc/Gyro nCS	nCS Pin of BMI160/BMA255.
	P0.09	Mag nCS	nCS Pin of BMM150.
	P0.10	Mag DRDY	DRDY Pin of BMM150.
	P0.14	Mag Interrupt	INT Pin of BMM150.
	P0.17	LED Red nEn	Current Sink for Red LED Channel.
	P0.21	LED Green nEn	Current Sink for Green LED Channel.
	P0.23	LED Blue nEn	Current Sink for Blue LED Channel.
	P0.08	LED White nEn	Current Sink for White LED Channel.
	P0.15	Proximity Interrupt	Interrupt Pin of TSL26711.

Table 3 Module Pin Mapping

3 Circuit and Sensor Details

3.1 High Current/Haptic Drive Circuit

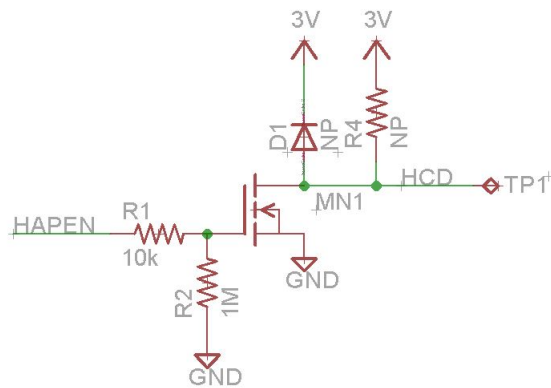

Figure 3 Haptic Driver Circuit

The haptic drive circuit features a logic level gate drive N-Channel MOSFET. Surface mount pads are available for a flyback diode or load resistance, but not populated at the factory. For driving a buzzer, a 1k resistor should be added. For driving a vibration motor, a flyback diode should be added. Please note that the standard CR2032 coin cell cannot supply enough current to drive a vibration motor. Both components are shipped unpopulated, so that a load device with voltage greater than +3V can be switched.

3.2 Humidity / Barometric Pressure Sensor

The Barometric Pressure Sensor BMP280 or the Humidity and Barometric Pressure Sensor BME280 is attached to the shared I²C bus at slave address 0x77.

3.3 Accelerometer / Gyroscope

The 6-axis accelerometer and gyroscope sensor BMI160, or the 3-axis accelerometer BMA255 is attached via the SPI bus, with pin numbers detailed in the module to SoC mapping table.

3.4 Ambient Light Sensor

The Ambient Light Sensor LTR-329ALS-01 is attached to the shared I²C bus at slave address 0x29.

3.5 Mechanical Switch

The GPIO internal pullup resistor should be used with the mechanical switch, which is active low.

3.6 Thermistor Temperature Circuit

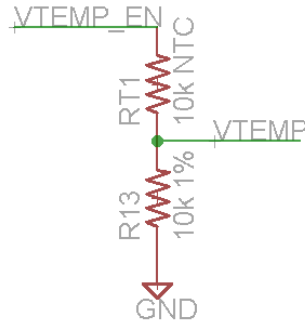

Figure 4 Thermistor Temperature Circuit

The thermistor circuit features a voltage divider and active high enable for power saving. Details on the sensor characteristics can be found in the data sheet for part number NCP15XH103F03RC.

3.7 RGB LED Circuit

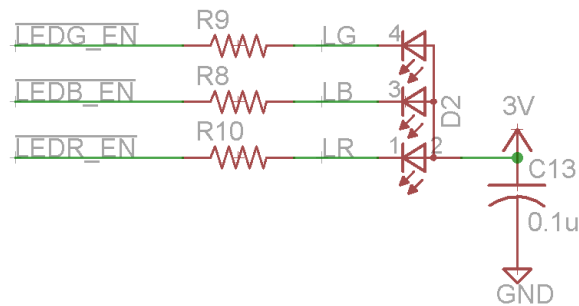

Figure 5 RGB LED Circuit

The RGB LED channels are driven by an active low PWM signal from the SoC. The resistance values have been chosen to approximately match intensity at 100 percent duty cycle. The high current bit should be set on the GPIOs to sink up to 5mA.

3.8 Optical Proximity Sensor

The Optical Proximity Sensor TSL26711 is attached to the shared I²C bus at slave address 0x39. The interrupt pin is connected as detailed in the SoC pin mapping table.

3.9 RGB Color Sensor

The RGB Color Sensor TCS34725 is attached to the shared I²C bus at slave address 0x29. A neutral color temperature white LED is provided for illuminating the sensing surface if necessary. The LED is connected as detailed in the SoC pin mapping table.

3.10 32Mhz High Frequency Crystal

If the MetaWear firmware is erased for native development, the SoC needs to be configured for use with the on board 32 MHz crystal. To do this you must write the value 0xFFFFFFFF to the UICR (User Information Configuration Register) at address 0x10001008. Please note that the UICR is erased whenever you download a SoftDevice.

The UICR can be written by using the debug tools:

```
nrfjprog.exe --snr <your_jlink_debugger_serial_number> --memwr 0x10001008 --val 0xFFFFFFFF
```

Or the following code can be added to the SystemInit function in the system_nRF51.c file, right before launching the TASK_HFCLKSTART task:

```
if (*(uint32_t *)0x10001008 == 0xFFFFFFFF)
{
    NRF_NVMC->CONFIG = NVMC_CONFIG_WEN_Wen << NVMC_CONFIG_WEN_Pos;
    while (NRF_NVMC->READY == NVMC_READY_READY_Busy){}
    *(uint32_t *)0x10001008 = 0xFFFFFFFF;
    NRF_NVMC->CONFIG = NVMC_CONFIG_WEN_Ren << NVMC_CONFIG_WEN_Pos;
    while (NRF_NVMC->READY == NVMC_READY_READY_Busy){}
    NVIC_SystemReset();
    while (true){}
}
```

4 Absolute Maximum Ratings

Spec	Description	Min.	Typ.	Max.	Units
V _{3V}	3V supply voltage.	-0.3		+3.6	V
V _{GND}	Ground voltage.			0	V
V _{IO}	I/O Pin Voltage.	-0.3		+3.6	V
T _{MAX}	Storage Temperature.	-40		125	°C

Table 4 Absolute Maximum Ratings

5 Operating Conditions

Spec	Description	Min.	Typ.	Max.	Units
V _{3V}	3V supply voltage.	2.7	3.0	3.6	V
T _A	Operating temperature.	-25	25	75	°C
I _{IDLE}	Idle current consumption.		10	25	uA

Table 5 Operating Conditions

6 Electrical Specifications

6.1 General Purpose I/O (GPIO) Specifications [C CPro CDetect CEnv]

Spec	Description	Min.	Typ.	Max.	Units
V _{IH}	Input high voltage.	2.1		3.0	V
V _{IL}	Input low voltage.	0		0.9	V
V _{OH}	Output high voltage.	2.7		3.0	V
V _{OL}	Output low voltage.	0		0.3	V
R _{PU}	Pull-up resistance.	11	13	16	kΩ
R _{PD}	Pull-down resistance.	11	13	16	kΩ

Table 6 General Purpose I/O (GPIO) Specifications

6.2 Crystal Oscillator Specifications (OSC) [C CPro CDetect CEnv]

Spec	Description	Min.	Typ.	Max.	Units
f _{HF,NOM}	High frequency crystal frequency		32		MHz
f _{HF,TOL}	High frequency crystal tolerance		±40		ppm
f _{LF,NOM}	Low frequency crystal frequency		32.768		kHz
f _{LF,TOL}	Low frequency crystal tolerance		±50		ppm

Table 7 Crystal Oscillator Specifications

6.3 ADC (ADC) Specifications [C CPro CDetect CEnv]

Spec	Description	Min.	Typ.	Max.	Units
DNL _{10b}	Differential non-linearity (10 bit mode).		<1		LSB
INL _{10b}	Integral non-linearity (10 bit mode).		2		LSB
V _{OS}	Offset error.	-2		+2	%
V _{REF_INT}	Internal reference voltage.	-1.5	1.20 V	+1.5	%
TC _{REF_INT}	Internal reference voltage drift.	-200		+200	ppm/°C
t _{ADC10b}	Sample conversion time (10 bit mode).		68		μs
t _{ADC9b}	Sample conversion time (9 bit mode).		36		μs
t _{ADC8b}	Sample conversion time (8 bit mode).		20		μs

Table 8 ADC Specifications

6.4 Temperature Sensor (TEMP) Specifications [C CPro CDetect CEnv]

Spec	Description	Min.	Typ.	Max.	Units
T _{RANGE}	Temperature sensor range.	-25		75	°C
T _{ACC}	Temperature sensor accuracy.	-4		+4	°C
T _{RES}	Temperature sensor resolution.		0.25		°C
T _{THM_RANGE}	Thermistor sensor range.	-25		75	°C
T _{THM_ACC}	Thermistor sensor accuracy.	-1		+1	°C
T _{THM_RES}	Thermistor sensor resolution.		0.125		°C

Table 9 Temperature Sensor (TEMP) Specifications

6.5 High Current Driver (HCD) Specifications [C CPro CDetect CEnv]

Spec	Description	Min.	Typ.	Max.	Units
I _{ON,SS25}	Steady state on current at 25°C.			310	mA
I _{ON,SS85}	Steady state on current at 85°C.			220	mA
P _{ON,SS}	Steady state power dissipation.			280	mW
I _{ON,PULSE}	Pulsed current for 10 μs.			1.4	A
R _{ON}	On state resistance.		2	5	Ω
I _{OFF,LEAK}	Off state leakage.			1	nA
V _{CLAMP}	Clamping diode voltage threshold.		3.3		V

Table 10 High Current Driver (HCD) Specifications

6.6 Accelerometer (ACCEL) Specifications [C CPro]

Spec	Description	Min.	Typ.	Max.	Units
	Measurement range.	±2		±16	g
	Resolution.	2048		16384	counts/g
f _{DATA}	Data sample frequency.	0.78		1600	Hz
I _{12.5}	Low data rate current (3.125 Hz).		5		uA
I ₁₀₀	Mid data rate current (100 Hz).		24		uA
I ₁₀₀	High data rate current (1600 Hz).		180	300	uA
I _{STANDBY}	Standby current.		3	10	uA

Table 11 Accelerometer (ACCEL) Specifications

6.7 Accelerometer (ACCEL) Specifications [CDetect CEnv]

Spec	Description	Min.	Typ.	Max.	Units
	Measurement range.	±2		±16	g
	Resolution.	128		1024	counts/g
f _{DATA}	Data sample frequency.	7.8		1000	Hz
I _{12.5}	Low data rate current.		6.5		uA
I ₁₀₀	Mid data rate current.		66		uA
I ₁₀₀	High data rate current (1000 Hz).		130		uA
I _{STANDBY}	Standby current.		2.1		uA

Table 12 Accelerometer (ACCEL) Specifications

6.8 Gyro (GYRO) Specifications [C CPro]

Spec	Description	Min.	Typ.	Max.	Units
	Measurement range.	±125		±2000	°/s
	Resolution.	16		262	counts/°
f _{DATA}	Data sample frequency.	25		3200	Hz
I _{GYRO}	Gyro active current. All Data Rates.		850	900	uA
I _{STANDBY}	Standby current. Included in Accel Standby Current.				

Table 13 Gyro (GYRO) Specifications

6.9 Pressure (BAROMETER) Specifications [CPro CEnv]

Spec	Description	Min.	Typ.	Max.	Units
	Measurement range.	30		110	kPa
	Resolution in ultra high resolution mode.		0.16		Pa
f_{DATA}	Data sample frequency at max data rate.			157	Hz
I_{ACTIVE}	Active current. Data rate and oversampling sensitive.	0.14		650	μA
$I_{STANDBY}$	Standby current.		0.1	0.3	μA
I_{PEAK}	Peak current during measurement.		720	1120	μA

Table 14 Pressure (BAROMETER) Specifications

6.10 Humidity (HYGROMETER) Specifications [CEnv]

Spec	Description	Min.	Typ.	Max.	Units
	Measurement range.	0		100	% RH
	Resolution.		0.008		% RH
A_H	Absolute accuracy tolerance.		± 3		% RH
I_{AVG}	Average current at 1Hz.		1.8	2.8	μA
$I_{STANDBY}$	Standby current.		0.2	0.5	μA
I_{PEAK}	Peak current during measurement.		340		μA

Table 15 Humidity (HYGROMETER) Specifications

6.11 LED (LED) Specifications [C CPro CDetect CEnv]

Spec	Description	Min.	Typ.	Max.	Units
I_{RGB}	Drive current per channel.	2	4	5	mA
λ_{RPEAK}	Red peak wavelength.		624		nm
λ_{GPEAK}	Green peak wavelength.		525		nm
λ_{BPEAK}	Blue peak wavelength.		470		nm
I_{VR}	Red luminous intensity.	12	60		mcd
I_{VG}	Green luminous intensity.	15	60		mcd
I_{VB}	Blue luminous intensity.	10	60		mcd
	Viewing Angle		120		$^{\circ}$

Table 16 LED (LED) Specifications

6.12 Ambient Light (ALS) Specifications [CPro CDetect]

Spec	Description	Min.	Typ.	Max.	Units
	Measurement range.	0.01		64k	lux
	Resolution.		16		bit
f_{DATA}	Data sample frequency.	0.5		20	Hz
I_{PEAK}	Peak active current.			220	μA
$I_{STANDBY}$	Standby current.			5	μA

Table 17 Ambient Light (ALS) Specifications

6.13 RGB Color + Ambient Light (COLOR, ALS) Specifications [CEnv]

Spec	Description	Min.	Typ.	Max.	Units
	Resolution.		16		bit
I_{PEAK}	Peak active current. Data rate and oversampling sensitive.		235	330	μA
$I_{STANDBY}$	Standby current.		2.5	10	μA
I_{LED}	Illumination LED current.		5		mA
	Illumination LED color temperature.		4400		K

Table 18 RGB Color Sensor (COLOR) Specifications

6.14 Proximity Sensor (PROX) Specifications [CDetect]

Spec	Description	Min.	Typ.	Max.	Units
I_{PEAK}	Peak active current.		175	250	μA
$I_{STANDBY}$	Standby current.		2.5	4	μA
I_{LED}	LED current.	12.5	12.5	100	mA
t_{PULSE}	LED pulse time.		7.2		μs
ϕ	LED beam half angle.		± 17		$^{\circ}$
λ_{PEAK}	LED peak wavelength.		860		nm
	Operating distance			18	in

Table 19 Proximity Sensor (PROX) Specifications

7 Mechanical Specifications

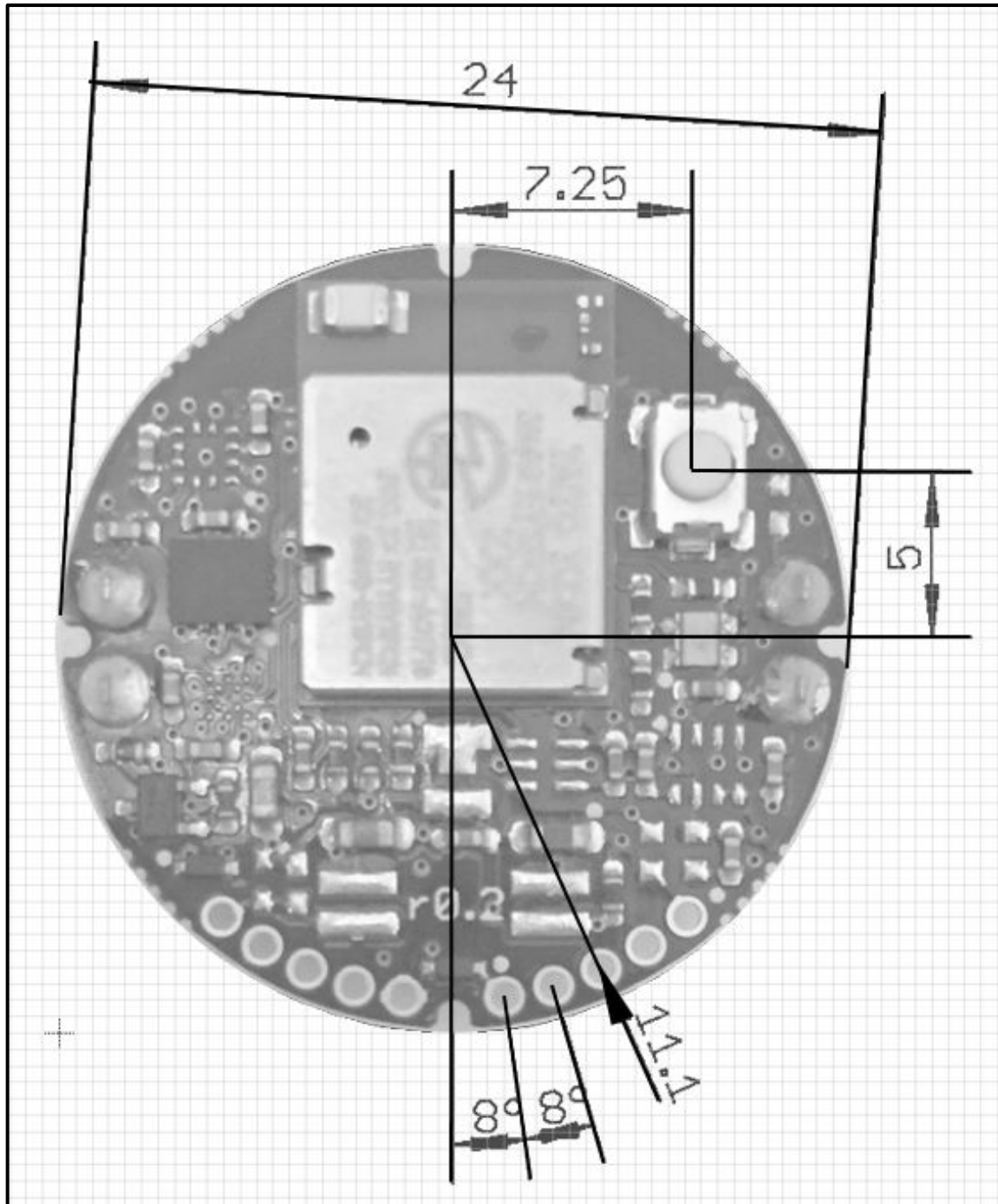

Figure 6 Module dimensions in mm

8 Revision History

Date	Version	Change Description
December 28, 2015	0.5	Initial Draft
January 3, 2018	1.0	Layout Changes

Table 20 *Revision History*

9 Regulatory Information for MetaWearC

9.1 Taiyo Yuden Radio Module Approval

The MetaWear RG and RPRO use the Taiyo Yuden module, part number EYSFCNZXX. The module is Bluetooth qualified, Telec (Japan), FCC, and IC (Canada) certified.

- Datasheet: http://www.yuden.co.jp/wireless_module/document/overview/TY_BLE_EYSFCNZXX_Overview_V1.0_20131225.pdf
- Bluetooth Listing: https://www.bluetooth.org/tpg/QLI_viewQDL.cfm?qid=21639
- IC: <https://industrycanada.co/number.php?ic=4389B-EYSFCN&id=171601>
- FCC: <https://fccid.io/RYYEYSFCN>

9.2 CE Conformance

The MetaWear C, CPro, CDetect, and CEnv boards are conformant to relevant CE specifications.

- Details: <https://mbientlab.com/docs/MetaWearDeclarationOfConformity.pdf>

9.3 FCC Labeling Requirements

If the FCC ID is not visible when the module is installed inside another device, then the outside of the device into which the module is installed must also display a label referring to the enclosed module. This exterior label can use wording such as the following: “Contains Transmitter Module FCC ID: RYY-EYSFCN” or “Contains FCC ID: RYY-EYSFCN”. Any similar wording that expresses the same meaning may be used.

9.4 IC Labeling Requirements

Labeling requirements for Industry Canada are similar to those required by the FCC. A clearly visible label on the outside of a non-removable part of the final product must include the following text: "Contains IC: 4389B-EYSFCN".

Les exigences d'étiquetage pour l'Industrie Canada sont semblables à ceux exigés par la FCC. Une étiquette bien visible à l'extérieur d'une partie non amovible du produit doit inclure le texte suivant: "Contains IC: 4389B-EYSFCN".